

10102 (MARK 1A) - U-JOINT PULLER

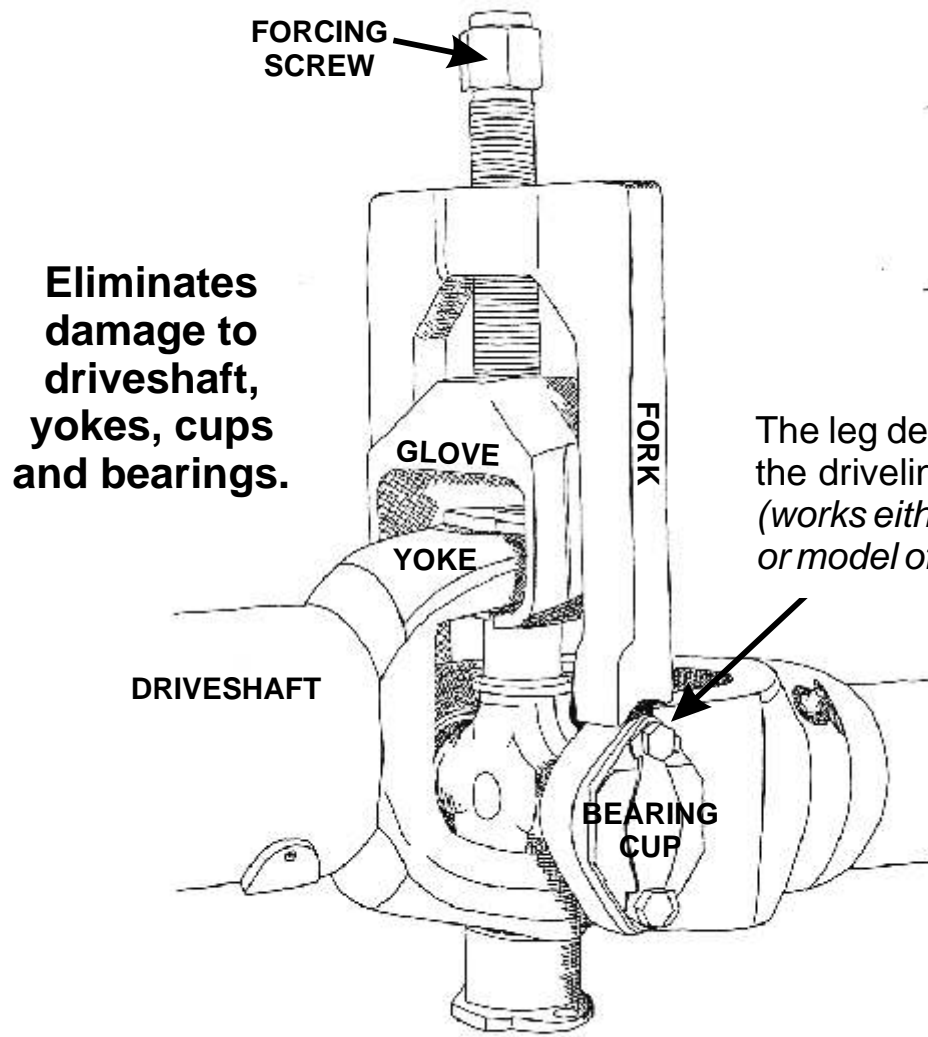

Eliminates damage to driveshaft, yokes, cups and bearings.

The leg design allows you to push on the driveline or on the U-Joint cross. (works either way on virtually any size or model of U-Joint)

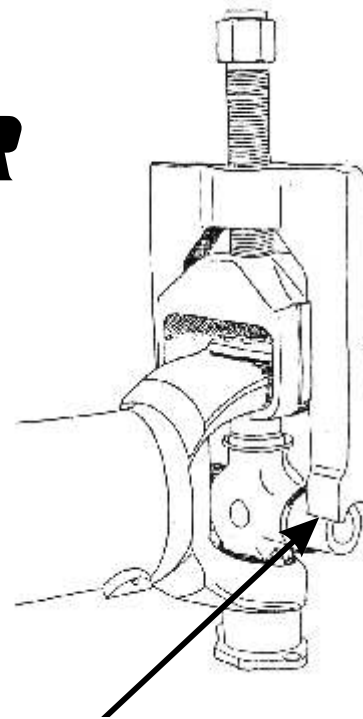

Lubrication

Use *prolong* "Anti Friction Metal Treatment" on threads and *prolong* "Superlube Grease" on load bearing surface in glove. For information on *prolong* Super Lubricants please call us.

OPERATING INSTRUCTIONS

- 1) Remove all fasteners from bearing cups.
- 2) Slip the U-Joint Puller over the yoke of the driveline.
- 3) Turn the tool's forcing screw clockwise with either an air or hand wrench. (Note: reverse thread)
- 4) Once bearing cup has been removed, repeat the process on the remaining bearing cups.

The 10102 U-Joint Puller may be used with up to a 1-inch impact wrench without voiding warranty.

U-JOINT PULLER CARE

- 1) Keep forcing screw clean and lubricated at all times. Failure to maintain the spherical thrust washer, located inside the glove will result in excessive wear to the part. Check and lubricate this part periodically and replace as necessary. Contact your Dealer or Tiger Tool for replacement washers. (We currently use and recommend Prolong SPL-100 lube for the threads and Prolong Superlube Grease).
- 2) To check washer, remove plastic protective cap located underneath the glove to expose retaining screw.
- 3) Secure the head of the forcing screw tightly in a vise. Then, using a 1 1/8" socket, rotate the retaining bolt counterclockwise to disassemble. The spherical thrust washer is easily checked by measuring the thickness and replaced if necessary. (New washer thickness .250"/ Recommended replacement .180").
- 4) Prior to re-assembly, insure the retaining screw, washer and glove are clean and free of old grease and dirt.
- 5) To reassemble, position the glove and fork so that the opening of the glove and the letters TIGER TOOL on the fork are facing in the same direction. Next, slide the glove into the fork and up into the forcing screw. Having added grease to both sides of the thrust washer, place the thrust washer onto the retaining bolt with the spherical side of the washer facing outward. Thread the retaining bolt clockwise through the glove and into the forcing screw and torque to approximately 120ft lbs. (No thread-locking compound is necessary, as the retaining bolt will self-tighten with use).

NOTE: FAILURE TO CHECK THE SPHERICAL THRUST WASHER AND REPLACE AS NECESSARY MAY RESULT IN UN-REPAIRABLE DAMAGE TO YOUR U-JOINT PULLER GLOVE CASTING. PREVENTATIVE MAINTENANCE AS OUTLINED ABOVE WILL ENSURE MANY YEARS OF USE FROM YOUR TIGER TOOL PULLER.

TIGER TOOL
International Incorporated

Phone: 1-800-661-4661