

20101/20100 (KIT 100) U-JOINT SERVICE KIT

U-JOINT PULLERS (PART # 10102, 10104, 10105)

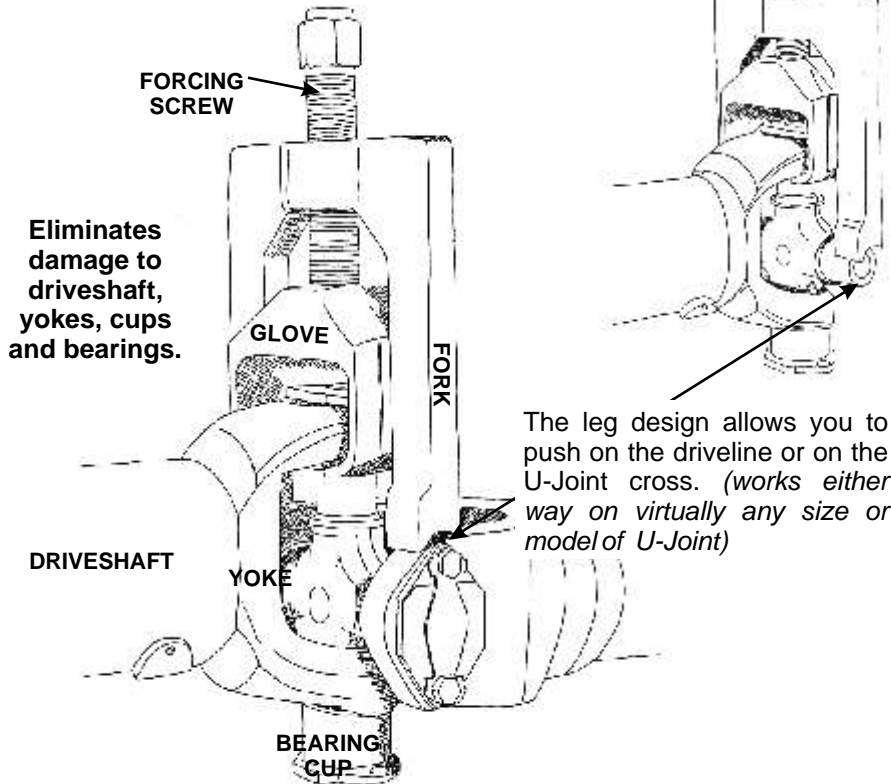

OPERATING INSTRUCTIONS

- 1) Remove all fasteners from bearing cups.
- 2) Slip the U-Joint Puller over the yoke of the driveline.
- 3) Turn the tool's forcing screw clockwise with either an air or hand wrench. (Note: reverse thread)
- 4) Once bearing cup has been removed, repeat the process on the remaining bearing cups.

The 10102 U-Joint Puller may be used with up to a 1-inch impact wrench without voiding warranty. The 10104 and 10105 U-Joint Pullers may be used with up to a ½ inch impact wrench without voiding warranty.

U-JOINT PULLER CARE

- 1) Keep forcing screw clean and lubricated at all times. Failure to maintain the spherical thrust washer, located inside the glove will result in excessive wear to the part. Check and lubricate this part periodically and replace as necessary. Contact your Dealer or Tiger Tool for replacement washers. (We currently use and recommend Prolong SPL-100 lube for the threads and Prolong Superlube Grease).
- 2) To check washer, remove plastic protective cap located underneath the glove to expose retaining screw.
- 3) Secure the head of the forcing screw tightly in a vise. Then, using a 1 1/8" socket, rotate the retaining bolt counterclockwise to disassemble. The spherical thrust washer is easily checked by measuring the thickness and replaced if necessary. (New washer thickness .250"/Recommended replacement .180").
- 4) Prior to re-assembly, insure the retaining screw, washer and glove are clean and free of old grease and dirt.
- 5) To reassemble, position the glove and fork so that the opening of the glove and the letters TIGER TOOL on the fork are facing in the same direction. Next, slide the glove into the fork and up into the forcing screw. Having added grease to both sides of the thrust washer, place the thrust washer onto the retaining bolt with the spherical side of the washer facing outward. Thread the retaining bolt clockwise through the glove and into the forcing screw and torque to approximately 120ft lbs. (No thread-locking compound is necessary, as the retaining bolt will self-tighten with use).

BEARING CUP INSTALLER (PART # 10201)

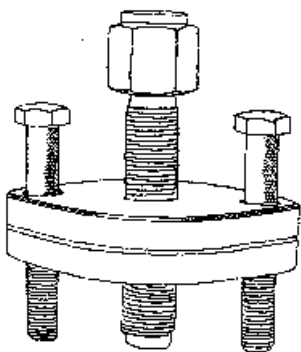

OPERATING INSTRUCTIONS

- 1) Ensure all parts to be assembled are clean and/or greased where applicable.
- 2) Double check all needle bearings are present and placed correctly.
- 3) Start pressing bearing cup into yoke by hand, making sure u-joint cross and bearing cup bolt holes line up.
- 4) Place installer onto bearing cup, threading bolts into yoke.
- 5) Using an impact or hand wrench, turn forcing screw until cup is flush to yoke.
- 6) Remove tool, and install bearing cup bolts.

NOTE: FAILURE TO CHECK THE SPHERICAL THRUST WASHER AND REPLACE AS NECESSARY MAY RESULT IN UN-REPAIRABLE DAMAGE TO YOUR U-JOINT PULLER GLOVE CASTING. PREVENTATIVE MAINTENANCE AS OUTLINED ABOVE WILL ENSURE MANY YEARS OF USE FROM YOUR TIGER TOOL PULLER.

Lubrication: Use Prolong "Anti Friction Metal Treatment" on threads and Prolong "Superlube Grease" on load bearing surface in glove. For information on Prolong Super Lubricants please call us.

TIGER TOOL *International Incorporated*
Phone: 1-800-661-4661